

# PELAGO BASKET® AND COMMUTER FRONT RACK® ASSEMBLY INSTRUCTIONS

## ASSEMBLY INSTRUCTIONS

Thank you for choosing Pelago product!  
 Please read the PRODUCT INFO box carefully before starting the assembly. Make sure all the parts are supplied in the sales package and you have prepared all needed tools for the assembly.

For extra assembly instructions go online:  
[www.pelagobicycles.com/instructions](http://www.pelagobicycles.com/instructions)

### 1 CHOOSING THE RIGHT MOUNTING COMPONENTS

1. Use suitable crown mounting bracket depending on front brake, fender, tire etc. size/model

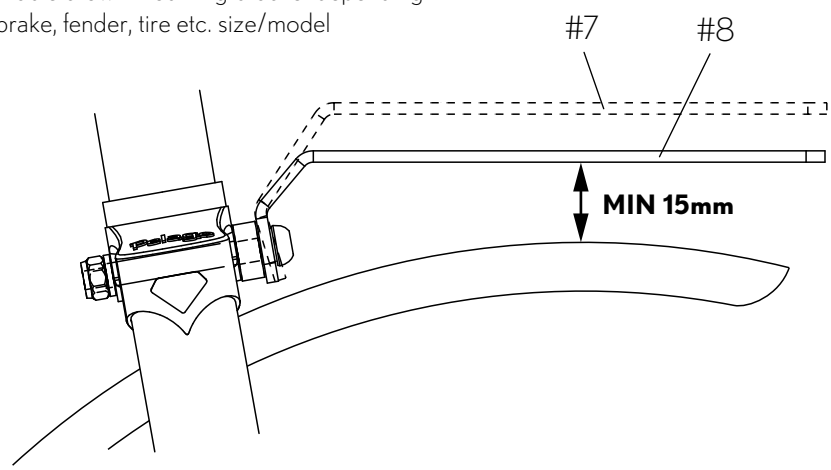

2. Use one pair of suitable dropouts depending on front fork end type

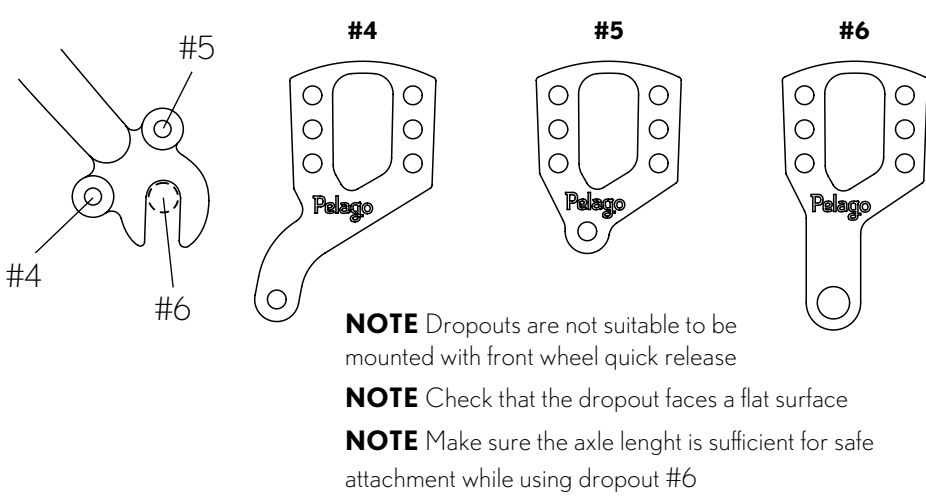

### 2 SIDESTAY ASSEMBLY

1. F-Markings must be facing outwards and on the front end of the rack.

2. Install the platform tabs between the Sidestay fork.

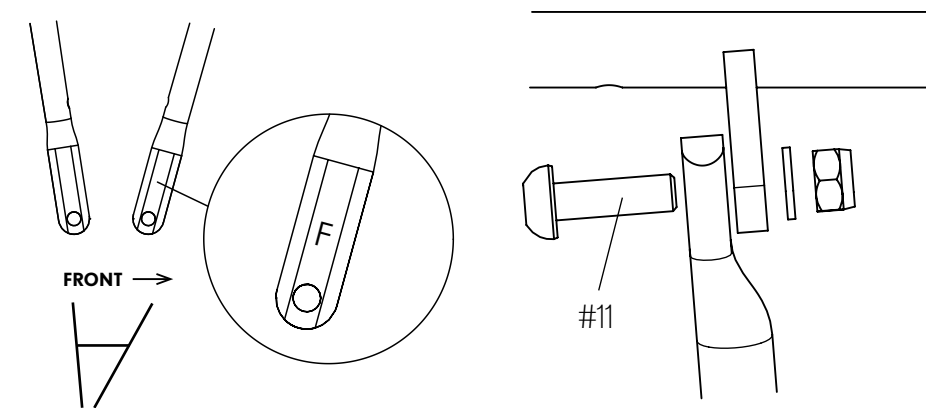

### 3 FORK CROWN BRACKET ASSEMBLY

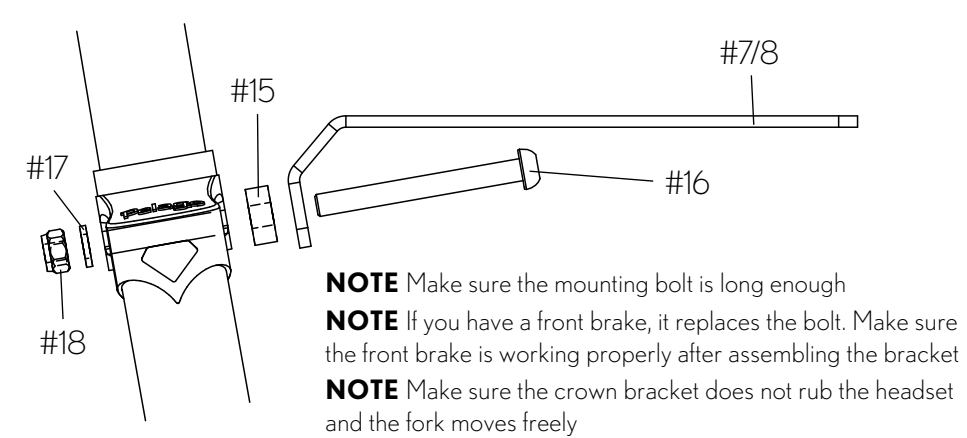

### 4 TESTING THE FIT

1. Check the platform angle

2. Check that there is enough clearance between the crown mounting plate and fender/tire

3. Check crown mounting bracket attachment position

NOTE For the best fit you might need to slightly bend the crown mounting bracket to reach the proper angle.

Check crown mounting bracket do-it-yourself adjustment figure

4. Check dropout mounting attachment position and height

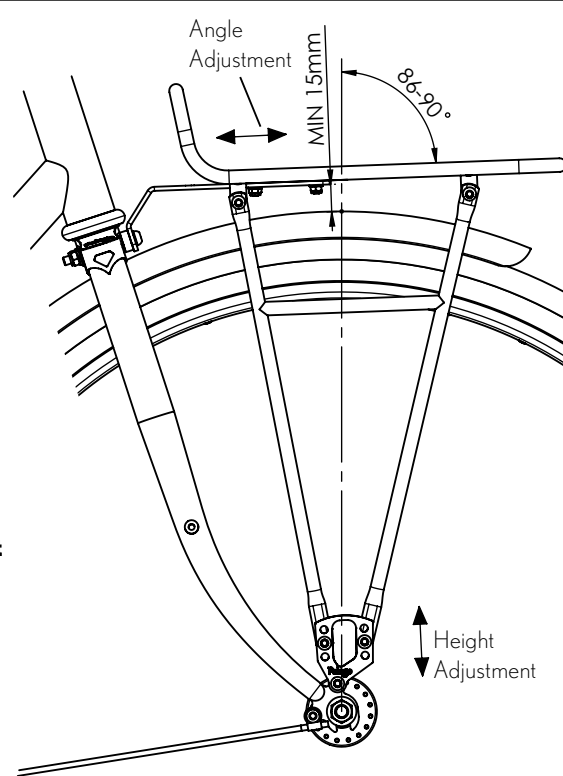

### 5 DROPOUT ASSEMBLY

1. Use appropriate mounting holes that will set the platform to best position and angle

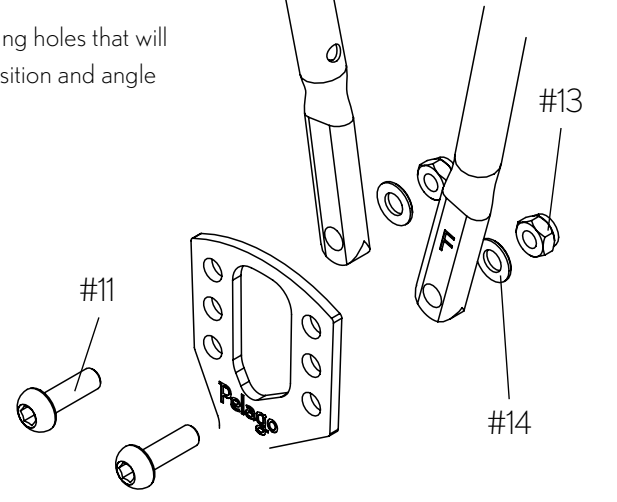

### 6 MOUNTING TO BICYCLE

1. Attach the platform to crown mounting bracket with 2 bolts

2. Mount the dropout to fork end or front hub axle

NOTE The alloy spacer (#15) is used with dropouts #4 and #5 only

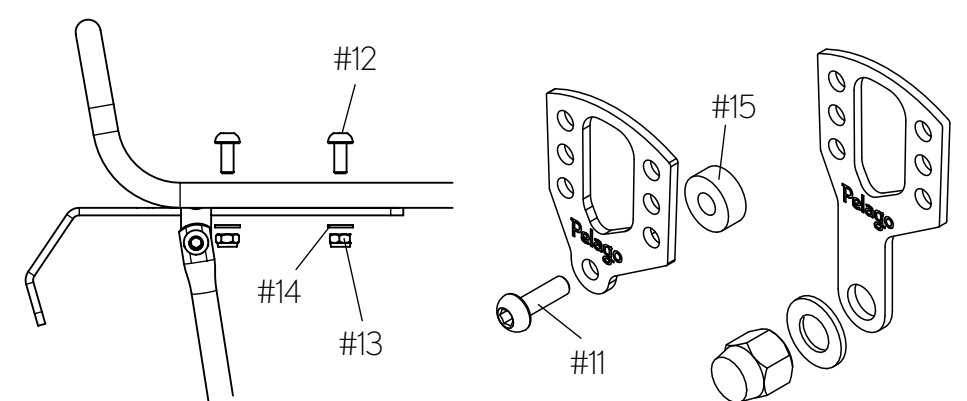

## EXPLODED VIEW

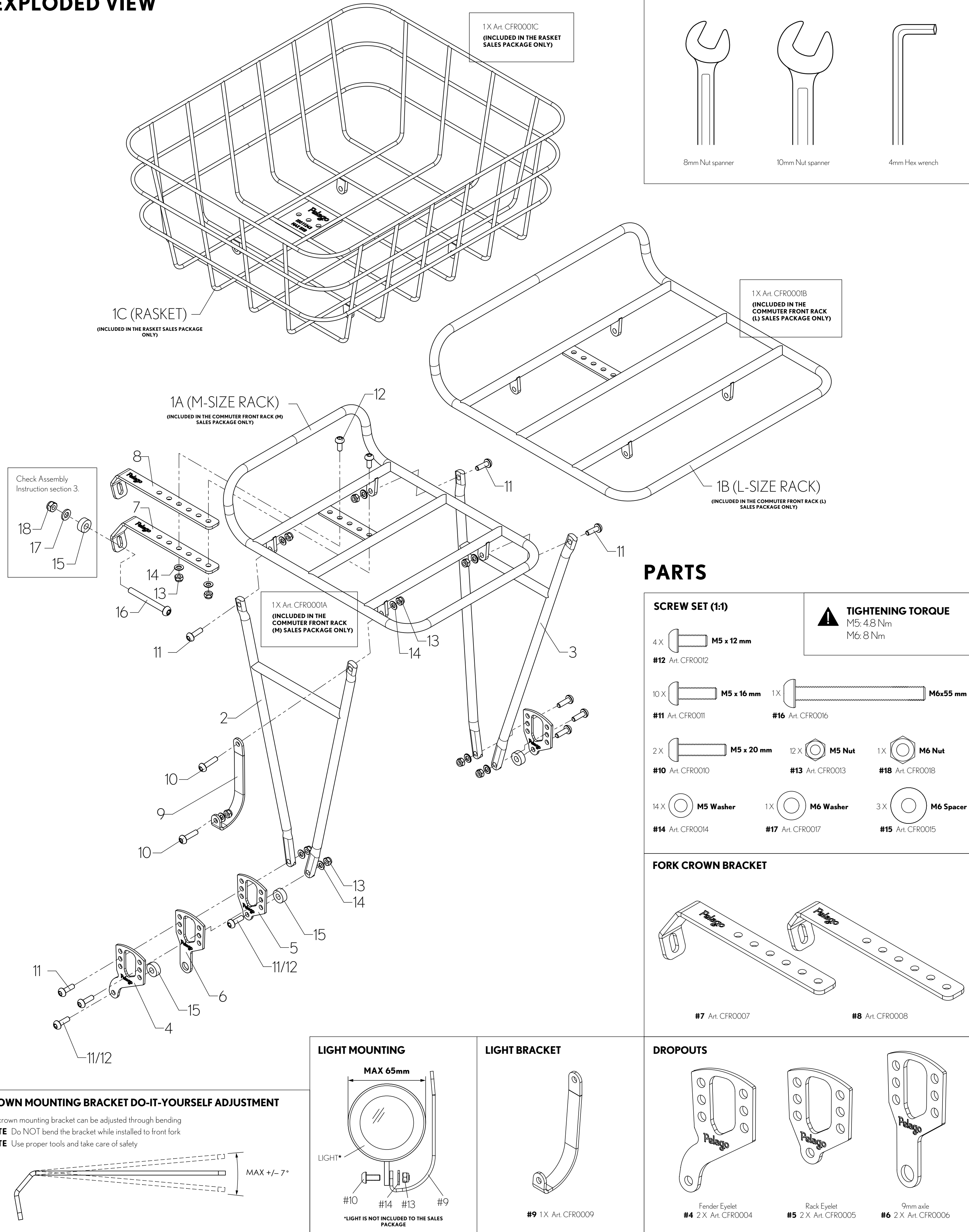

### REQUIRED TOOLS (NOT INCLUDED IN SALES PACKAGE)

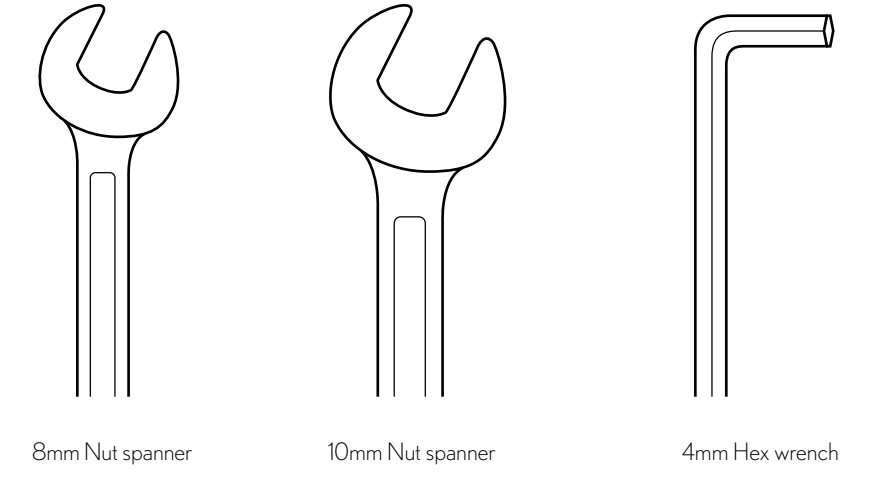

## PARTS

### SCREW SET (1:1)

4 X	M5 x 12 mm	#12 Art. CFR0012	<b>TIGHTENING TORQUE</b> M5: 4.8 Nm M6: 8 Nm
10 X	M5 x 16 mm	#11 Art. CFR0011	
1 X	M6 x 55 mm	#16 Art. CFR0016	
2 X	M5 x 20 mm	#10 Art. CFR0010	
12 X	M5 Nut	#13 Art. CFR0013	
1 X	M6 Nut	#18 Art. CFR0018	
14 X	M5 Washer	#14 Art. CFR0014	
1 X	M6 Washer	#17 Art. CFR0017	
3 X	M6 Spacer	#15 Art. CFR0015	

### FORK CROWN BRACKET

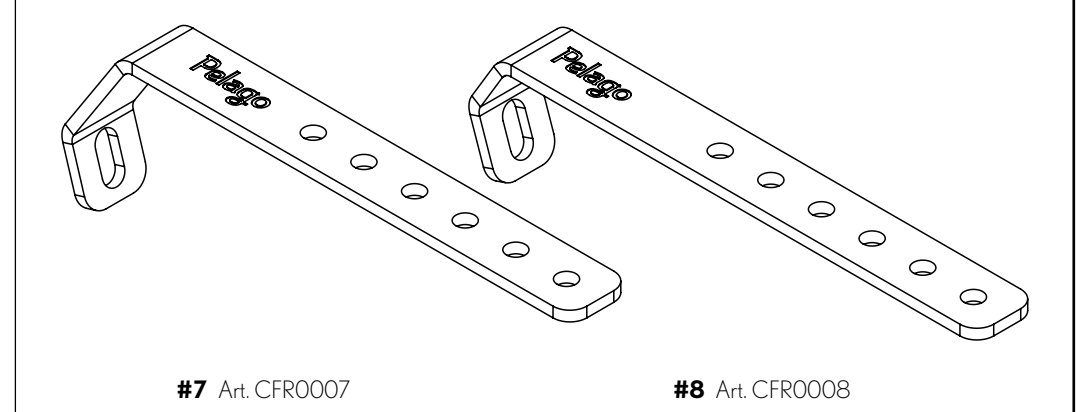

### DROPOUTS

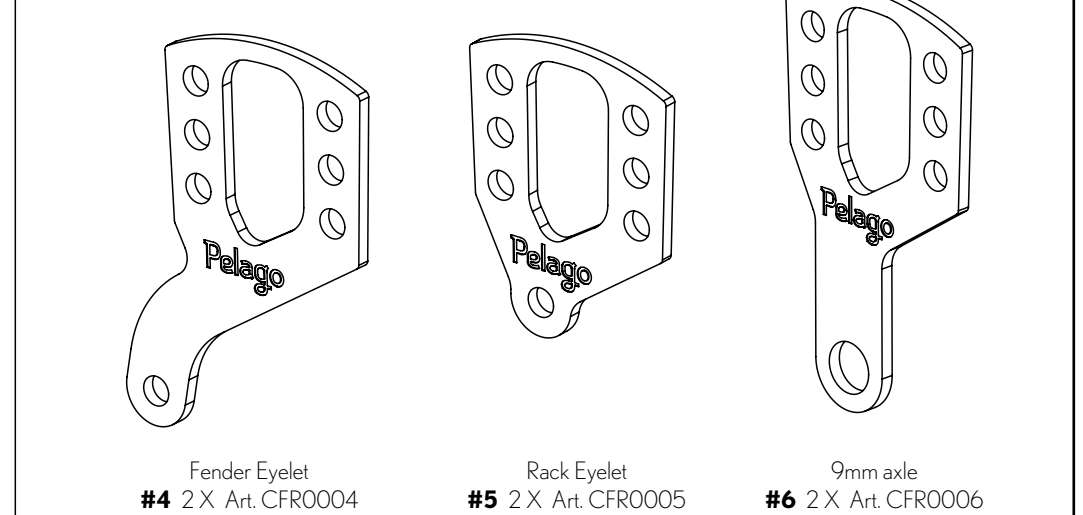

### SIDESTAYS

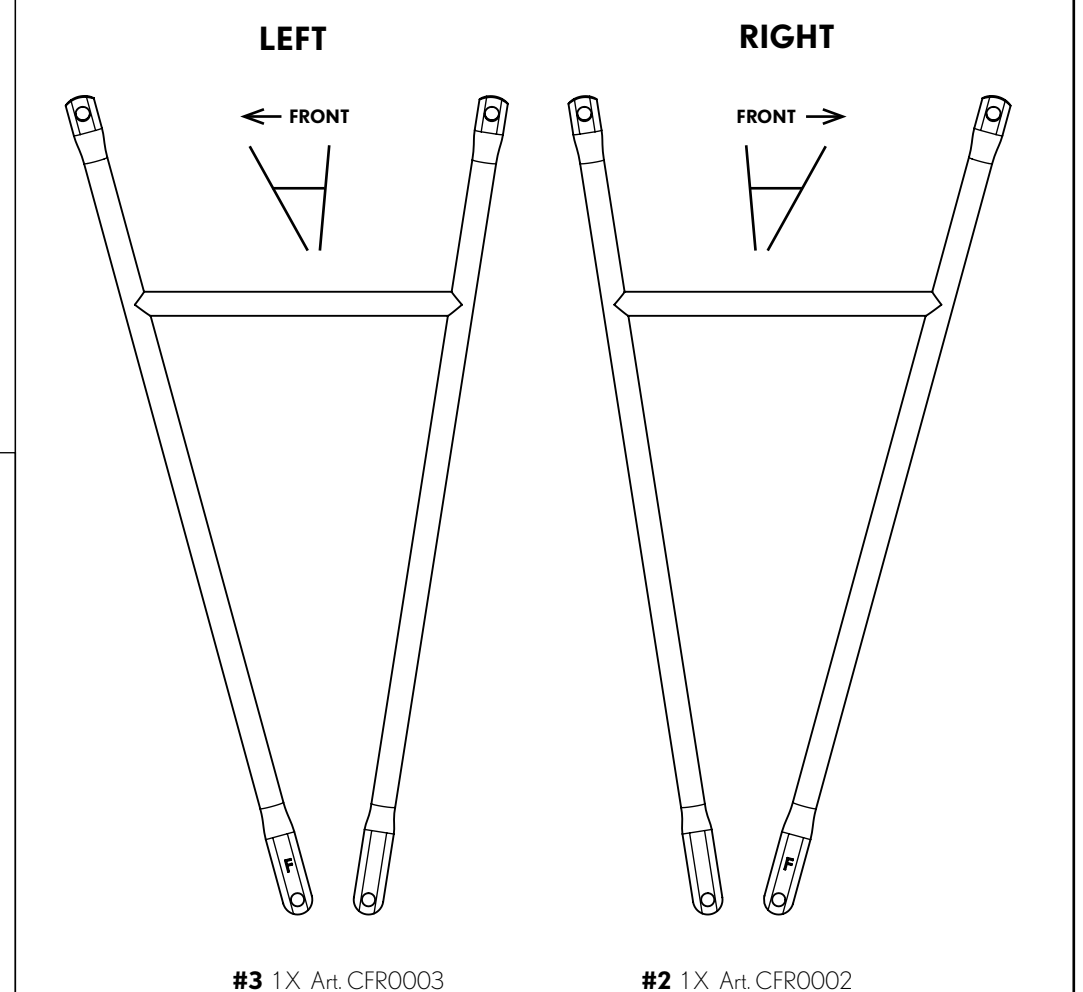

### CROWN MOUNTING BRACKET DO-IT-YOURSELF ADJUSTMENT

The crown mounting bracket can be adjusted through bending  
 NOTE Do NOT bend the bracket while installed to front fork  
 NOTE Use proper tools and take care of safety

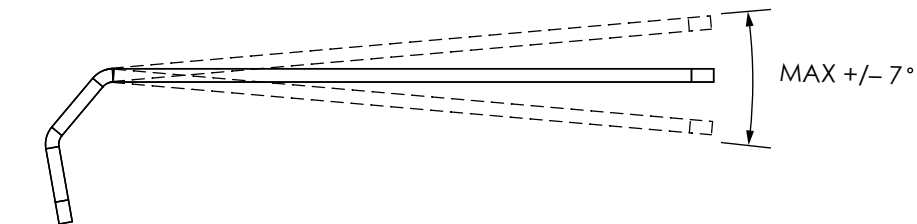

### PRODUCT INFO

#### PLEASE TAKE NOTE BEFORE ASSEMBLING THE RACK TO YOUR BICYCLE

1. Make sure your bicycle has the necessary eyelets to mount this rack.
2. The rack is designed to fit bicycles with 26", 650B and 700C wheels.
3. Make sure that your bicycle is strong and stable enough to carry a rack and its load.
4. This product is not designed to carry any people or animals.
5. The package includes small parts - Keep away from children under 3yrs.
6. Follow the assembly instructions carefully.
7. In any assembly problem turn to a professional bicycle mechanic.
8. Any kind of structural changes made to the rack are strictly forbidden.
9. Improper assembly can lead to product failure.

#### PLEASE TAKE NOTE WHEN RACK IS IN REGULAR USE

1. Make sure you don't exceed the total load of your bicycle or rack.
2. Check the tension of all rack and bicycle attachment points regularly.
3. Tighten all bolts to their stated Nm torques. A precise tightening torque will be achieved with a torque wrench.
4. Do not attach a child seat to the rack. The rack is not approved to carry children or adults.
5. Do not attach any pressure- or clamp-style attachments to any parts of the rack.
6. Any type of physical or technical alterations to the rack are strictly forbidden.
7. Make sure there are no loose straps or cords that could be caught in the front wheel while in motion.
8. Make sure that luggage weight is distributed as evenly as possible.
9. Make sure that all required reflectors and lights are visible and not covered by racks or luggage.
10. Remove all luggage from racks when transporting a bicycle in any vehicles.

#### WARRANTY

1. Guarantee of a Pelago rack applies only to total product failure or breakage.
2. Any other damage resulting from scratches, rust, improper mounting or deformation are excluded from the warranty.
3. Only the original owner of the product is entitled to make a guarantee claim.

Liability arising from errors or mistakes is NOT accepted.  
 Pelago reserves the right to any changes without prior notice.

#### THE WEIGHT LIMITS

Rack platform	5 kg
Rasket platform	5 kg
Sidestay, Right	5 kg
Sidestay, Left	5 kg
<b>Total weight limit</b>	<b>15 kg</b>

DO NOT EXCEED THE WEIGHT LIMITS

#### MANUFACTURER

**Pelago**  
 BICYCLES

Pelago Mfg Ltd.  
 Helsinki, Finland  
 info@pelagobicycles.com  
 TEL +358 (0)45 1616847

SERVE THE PURPOSE



FIRMITAS

Pelago<sup>®</sup>  
BICYCLES  
UTILITAS VENUSTAS

DAZZLING RACKS FOR STUNNING LIFE